

BERLIN MIXER STAND

FOOD & LAB EQUIPMENT CO.
Performance through stainless!

Performance Through Stainless!

877-499-4231

43 SOUTH LINDEN AVE. SOUTH SAN FRANCISCO, CA 94080 PH (650) 589-4231 FAX (650) 589-3981 WWW.BERLINUSA.COM

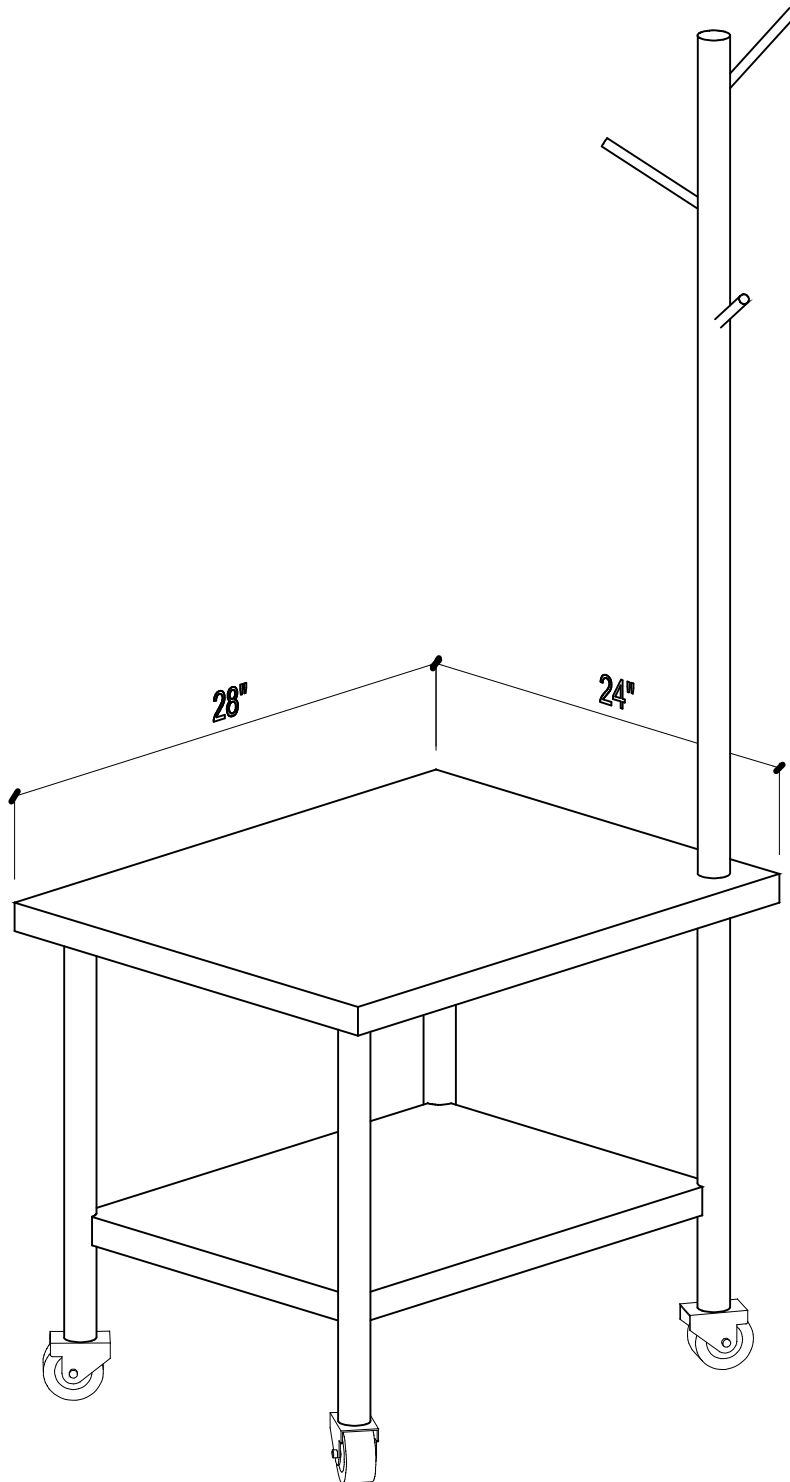

MADE IN
THE U.S.A.
CERTIFIED
TO ANSI

SPECIFICATIONS

STA - PRO MXS SERIES MIXER STANDS ARE CONSTRUCTED WITH A FULL PERIMETER, HEAVY ANGLE IRON FRAME TO SUPPORT THE 16GA. TYPE 304 STAINLESS STEEL, SOUND DEADENED TOP. LEGS ARE 1.625" O.D. STAINLESS STEEL TUBE WITH N.S.F. ADJUSTABLE BULLET FEET (MODEL # MXSS) OR CASTERS (MODEL # MXSM). THE LEGS ARE WELDED TO THE PERIMETER FRAME. THE 18GA. STAINLESS STEEL UNDERSHELF IS REINFORCED WITH A 16GA. CHANNEL AND IS FULLY WELDED AT EACH LEG 8" ABOVE THE FLOOR. THE UTENSIL TREE IS 1.625" O.D. STAINLESS STEEL WITH FIVE STAINLESS STEEL PRONGS.